



# SO-1290 ASSEMBLY INSTRUCTIONS

STEP 1 to 2 

STEP 3 to 5 

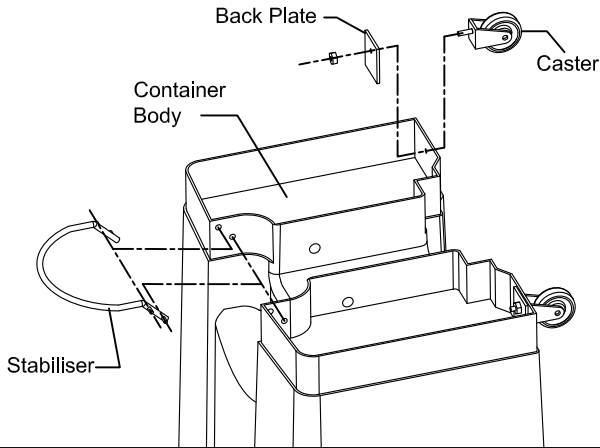

illustration 1-1

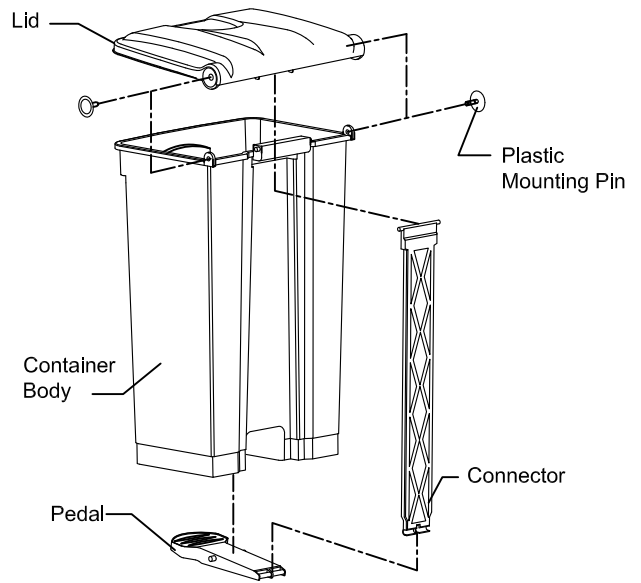

illustration 4-1

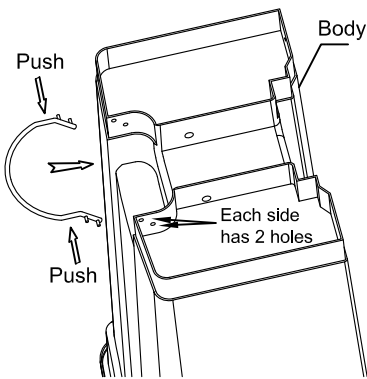

illustration 2-1

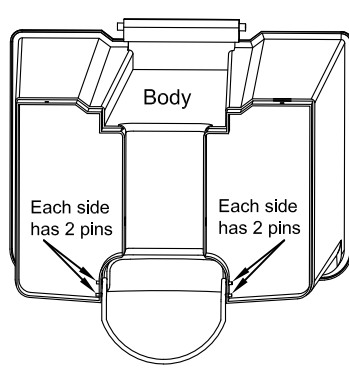

illustration 2-2

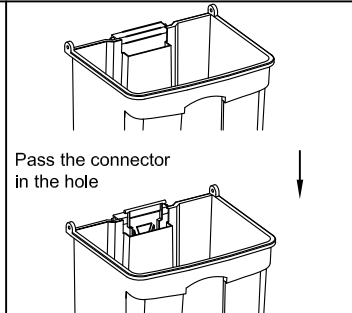
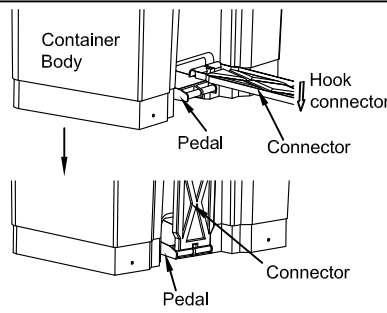
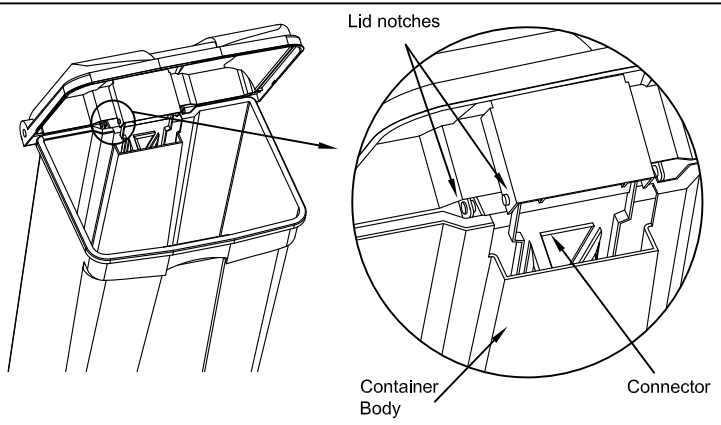
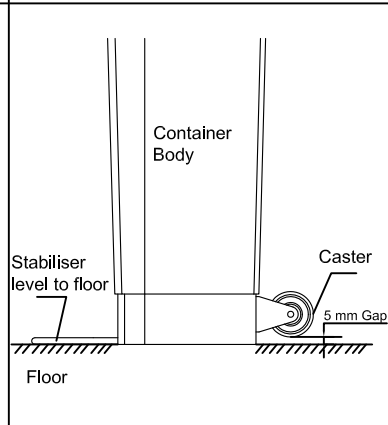
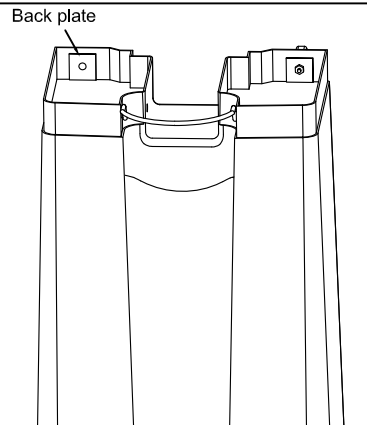

illustration 5-1



## Step 1 Assemble Stabiliser:

Place container body upside down. Push stabiliser from both sides to bend it (see illustration 1-1), Insert stabiliser pins in holes (see illustration 1-2). Stabiliser should be leveled to the floor (see illustration 2-2).

## Step 2 Assemble Casters:

Position back plate (see illustration 2-1) - insert caster, nut and bolt and tighten with spanner - there is a 5mm gap between the caster and the floor (see illustration 2-2).

## Step 3 Assemble Pedal:

Place the container upside down. Place the pedal in position, making sure that the foot part of the pedal is oriented towards the front of the container. Insert the pedal pins in the corresponding notches located at the bottom of the container.

## Step 4 Assemble Connector:

Connect the lower end of the connector to the back of the pedal with the hook facing out. Pass the connector through the opening located at the top of the container back panel (see illustration 4-1).

## Step 5 Assemble Lid:

A rubber hammer may be needed for this step.

Place the lid on the top of the container. Squeeze the top end of the connector into the corresponding holes located on the inner side of the lid. (see illustration 5-1). Insert the mounting pins into the hinges on both sides of the lid.